

REAR VIEW ROTATED

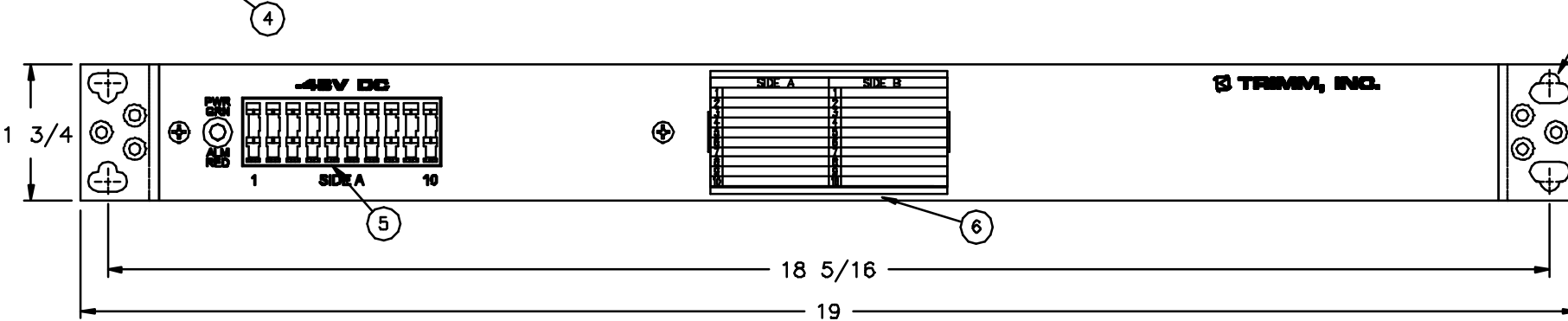

NOTES:

1. INPUT - SET SCREW STYLE WITH DUAL INPUT - 6 AWG MAX WIRE SIZE. RECOMMENDED TORQUE 14 in-lbs
2. EQUIPMENT CONNECTIONS - SET SCREW TYPE ACCEPTS 26-14 AWG. RECOMMENDED TORQUE 8 in-lbs.
3. ALARM CONTACTS - SET SCREW TYPE ACCEPTS 26-14 AWG. 125 VDC OR 125 VAC. MAXIMUM SWITCHING POWER 30 WATTS DC OR 60 VA AC (RESISTIVE LOAD). RELAY CHANGES STATE WHEN FUSE FAILS ONLY. RECOMMENDED TORQUE 8 in-lbs.
4. ALARM/POWER INDICATOR - RED/GREEN LED TYPE.
5. FUSE HOLDER - ACCEPTS GMT TYPE FUSES UP TO 15 AMPS PER POSITION (60 AMPS MAX)
6. DESIGNATION - CARD FOR EQUIPMENT/FUSE IDENTIFICATION.
7. MOUNTING - FLUSH, 4 OR 5 INCH MOUNTING. 19 AND 23 INCH MOUNTING BRACKETS INCLUDED.
8. FINISH - CLEAR ANODIZE STANDARD. OTHER FINISHES AND CUSTOM SILK-SCREENS CAN BE SUPPLIED.
9. PANEL CAN BE SUPPLIED WITH FUSES INSTALLED.

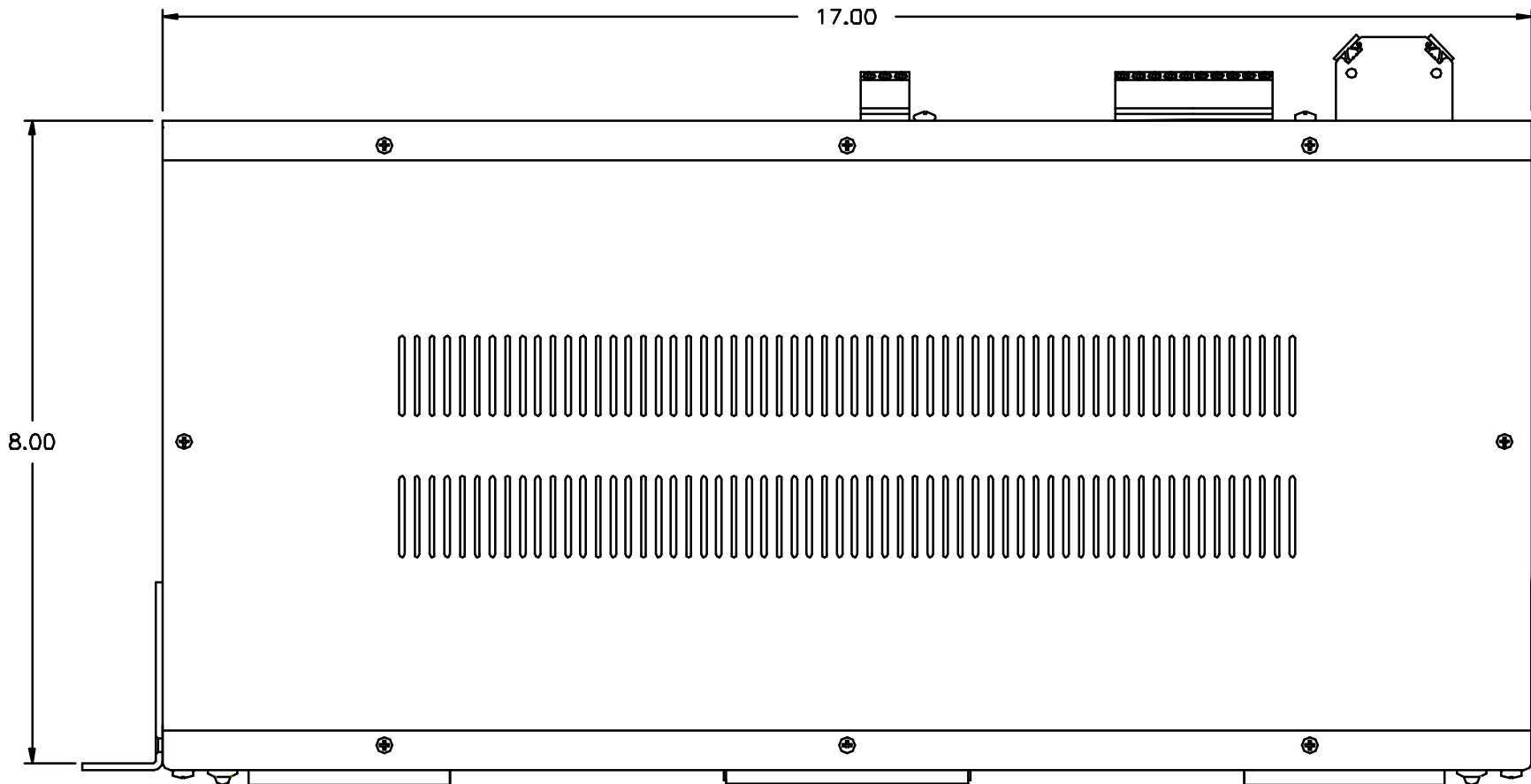
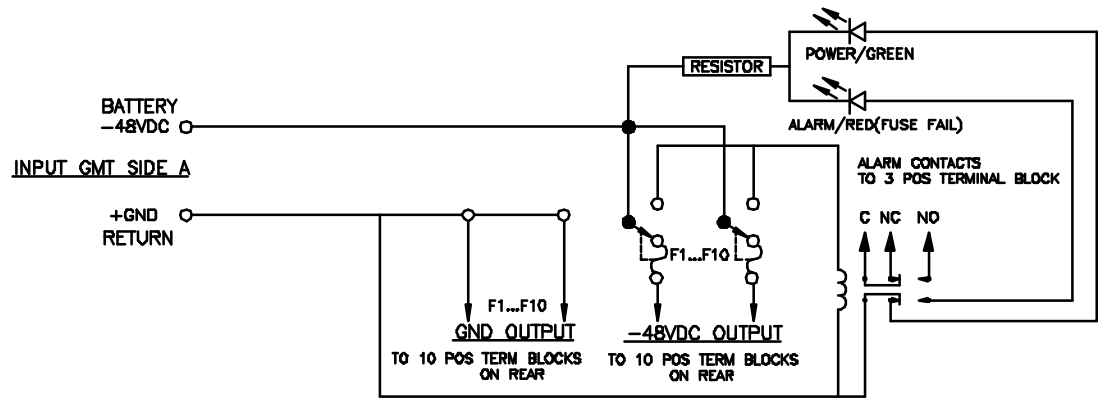

1/4 X 1/2  
SLOT TYP  
4 PLACES

| PART NUMBER | VOLTAGE    |
|-------------|------------|
| 7570418001  | 7570418001 |
| 7570418002  | 7570418002 |
| 7570418003  | 7570418003 |
| 7570418004  | 7570418004 |

|             |      |            |      |          |          |   |              |             |           |          |
|-------------|------|------------|------|----------|----------|---|--------------|-------------|-----------|----------|
| APPROVED BY | DATE | CHECKED BY | DATE | DRAWN BY | DATE     | FUSE PANEL OV-BOX 10 POSITION<br>SET SCREW IN/OUT, -48VDC SHOWN |              |             |           |          |
|             |      |            |      |          |          | SIZE  | FILE CODE    | DRAWING NO. | REV/ISSUE |          |
|             |      |            |      | B. BURCH | 08/28/00 | B   | MKT          | 7570418000  | A         |          |
|             |      |            |      |          |          | PHONE:  | LIBERTYVILLE |             | FAX:      | ILLINOIS |
|             |      |            |      |          |          | <b>TRIMM, INC.</b>  |              |             |           |          |