



High Current Fuse Panel Installation Guide

This manual covers the following part numbers-

Trimm **767xxxxxx** Family

Verizon Material ID's 11066357, 11066358, 11066359, 11066360

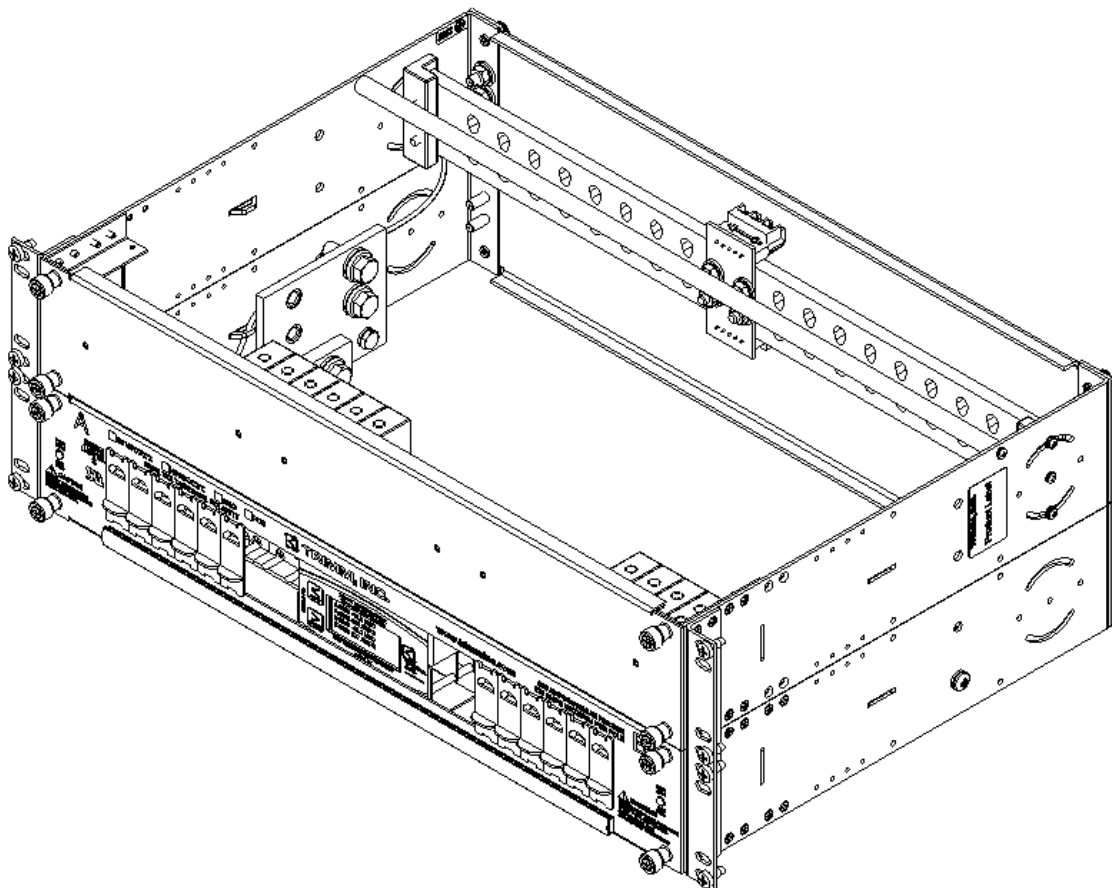

Table of Contents

Section 1- General Information	3
1.1 - Product Description	3
1.2 - Inspection	3
1.3 - What's Included.....	3
Section 2 – Before You Begin	3
2.1 - Tools Required For Installation	3
2.2 - Input Bus Amperage Rating	4
2.3 - Fuse Sizing Information	4
2.4 – Fuse/Circuit Breaker Replacement Information	4
2.5 - Wiring Temperature Information	4
2.6 - General Notes on Terminal Connections	4
2.7 - Terminal Information	4
Section 3 – Rack Mounting	5
3.1 - Rack Mounting	5
3.2 - Additional Rack Mounting Instructions.....	5
Section 4 – Input and Grounding Cabling	5
4.1 - Chassis Grounding (Earthing).....	5
4.2 - Input Wiring (Battery Connection)	5
4.3 - Input Wiring (Return Connection).....	5
4.4 - Power Verification Test	5
4.5 - Smart Meter Module.....	6
Section 5 – Output and Alarm Cabling.....	6
5.1 - Output Wiring	6
5.2 - Output Wiring (GMT Modules Barrier Strip Type).....	6
5.3 - Output Wiring (GMT Modules Set Screw Type).....	6
5.4 - Alarm Wiring.....	6
5.5 - Plastic Rear Safety Cover Installation.....	6
Section 6 – Final Installation	6
6.1 - Fuse Installation	7
6.2 - Energizing the Panel	7
Section 7 – Accessories.....	7

Section 1- General Information

1.1 - Product Description

Trimm, Inc.'s high current DC power distribution unit offers a modular design for those needing fused protection from .18 Amps to 250 Amps per position (600 Amps maximum per bus). This unique flexible design accepts many standard telecommunication fuse types as well as single and dual pole circuit breakers. With its modular design it's easy to add more modules in the field as the need arises. This unit is available in a compact 2U or 4U rack space configuration. Power and alarm status are displayed locally with relay contacts for remote fuse fail and power failure indication. An optional meter module allows voltage, current and remote temperature readings to be displayed locally as well as acting as an SNMP agent to send failure traps and respond to manager request strings. Voltage, current and temperature readings are also viewable via an integrated web server as a web page. This product is suitable for use in central office locations, network telecommunication facilities and data centers.

1.2 - Inspection

Inspect the panel for any noticeable defects, missing parts (See "What's Included" below), or shipping damage. Please notify Trimm, Inc. if any problems are found at 1-800-298-7466. No products may be returned to Trimm, Inc. without the proper Return Material Authorization (RMA) number.

1.3 - What's Included

- This unit should be packaged with the following items. Please notify Trimm, Inc. if any of these items are not included so a replacement can be sent out right away.
- High current panel (verify part number from sticker on right side of unit.)
- 4 x #12-24 x 1/2" self-tapping mounting screws (8 for the 4U configuration)
- Fasteners for input (battery and return) and output connections (equipment return bus hardware not included)
- 1/4" bolt and washer kit (For chassis ground connection.)
- Installation instruction packet

Other items in shipping box may include

- Installed fuses/circuit breakers
- Meter module w/current sensors
- Temperature sensors

Section 2 – Before You Begin



This panel should be installed in a restricted access area by qualified service personnel only.

All connections/methods should meet all national/local electrical codes as well as company specific methods or procedures. Failure to do so may result in damage to the equipment, and or personal injury.

A readily accessible disconnect device must be incorporated into the supply wiring for this product. This disconnect device must be capable of interrupting the maximum available fault current determined by analysis for your system.

2.1 - Tools Required For Installation

- Depending on the part number ordered the following tools are needed to install this product.
- Multimeter
- No. 2 Phillips head torque screw driver
- Torque wrench with 9/16 socket
- Suitable crimp tooling for the terminals
- Cable ties or lacing cord

Copyright © Trimm, Inc. All rights reserved.

INS-767xxxxxxV Rev C. 03/31/09 High Current Power Distribution Installation Instructions

- Writing utensil or label maker for circuit designation
- Wire wrap tools (for remote alarm wiring)

2.2 - Input Bus Amperage Rating

This product was designed to be used at its input bus amperage rating of 600 Amps, fed by a 2 x 750 MCM wire and protected by a 750 Amp maximum overcurrent device. If your required circuit rating is below that, you may size the input wire and interrupt/overcurrent device according to your needs per the National Electrical Code NFPA 70 ampacity tables or your local/company methods and procedures. In the event that this product and its associated wiring/overcurrent device are under the minimum rating, you should re-label over the panel's input bus rating to prevent accidental circuit overloading in the future.

2.3 - Fuse Sizing Information

The fuse manufacturer recommends that GMT fuses rated 8 to 15 Amps be continuously operated at no more than 70% of their nominal current rating. All fuse types/amperages may be continuously operated at 80% of their nominal current rating.

2.4 – Fuse/Circuit Breaker Replacement Information

The correct fuses or circuit breakers may be ordered from the table at the end of this document. See section 7

2.5 - Wiring Temperature Information

The wiring for this product should be rated 90° C or better.

Wiring protected by GMT fuses shall be at least one size larger than the minimum required wire based on the National Electric Code, NFPA 70 ampacity tables.

2.6 - General Notes on Terminal Connections

- Bare conductors should be coated with appropriate antioxidant compound before crimp connections are made.
- Use appropriate shrink tubing over un-insulated terminal barrels.
- Ensure that the mating surface of both the terminals and their connection point are clean and free of paint.
- Appropriate antioxidant should be applied to the mating surfaces of all connections.
- Use only listed terminals and crimp tooling when making connections.

2.7 - Terminal Information

The following terminals or suitable equivalents may be used for connection to this product. Only listed terminals and their recommended crimping tooling should be used. These recommendations are based on the panel's bus amperage rating.

767xxxxxx Family Suggested Field Wiring Terminals (Code wire)						
Connection	Manufacturer†	Manf. Part Number	Wire Gauge	Stud Size	Hole Spacing	Max. Width
Input	Panduit	LCDN750-38D	750 MCM	3/8"	1"	2"
Output	Panduit	LCD2-14A	2 AWG	1/4"	5/8"	.625"
Output (GMT modules)	Panduit	PV10-6RX	10/12 AWG	#6	Single Hole	.312"
Chassis Ground	Panduit	LCD2-14A	2 AWG	1/4"	5/8"	1"
Remote Alarm	Wire Wrap (Non required)					
<i>† The above list is only a suggestion. Equivalent terminals may be used provided they are listed and crimped with the appropriately listed crimp tooling.</i>						

Section 3 – Rack Mounting

3.1 - Rack Mounting

Secure the panel to the rack using the self tapping screws provided.

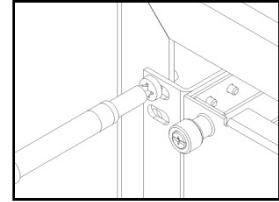

3.2 - Additional Rack Mounting Instructions

If installed in a closed or multi-unit rack assembly, the operating ambient temperature of the rack environment may be greater than room ambient.

Therefore, consideration should be given to installing the equipment in an environment compatible with the unit's maximum operating temperature. Mounting of the equipment in the rack should be such that a hazardous condition is not achieved due to uneven mechanical loading.

Section 4 – Input and Grounding Cabling

WARNING

Before installation, verify that the input power disconnect device is turned “OFF”.

4.1 - Chassis Grounding (Earthing)

This product is suitable for use in either a Common or Isolated (CBN or IBN) Bonding Network. Crimp the ground wire to the terminals provided. Attach the wires to the panel using the supplied bolts and lock washers. Torque fasteners to 50 in-lbs. Attach other end of ground pigtail to the rack or other suitable grounding location. Reliable Earthing of rack-mounted equipment should be maintained.

4.2 - Input Wiring (Battery Connection)

Crimp the battery wires to the proper terminals. Attach the battery input wires to the panel using the supplied flat washers and bolts. Torque the fasteners to 150 in-lbs. This product is suitable for use with either common or isolated (DC-C or DC-I) treatment of the battery return connection.

4.3 - Input Wiring (Return Connection)

This unit includes a rotating bus bar assembly which may be tilted up to 45 degrees forward or backwards to facilitate easier wire routing. Decide which position is right for your application and adjust the bus bar if necessary by simply loosening (but not removing) the screws securing both sides of the assembly on the side of the panel. After the position has been set re-torque the fasteners to 3 in-lbs.

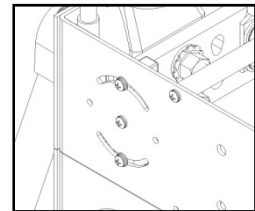

Fasteners are not included for any of the return connections to this panel. The return bus bar has teardrop shaped holes which allow #3/8 stud x 1” center-center distance or #1/4 stud x 5/8” center-center distance lugs. Crimp the return wire to the proper compression lug. Attach the wire to the return input bus bar. Wires may be attached on both sides of the return bus bar unless specifications require a dedicated connection. (Example: CO ground connection)

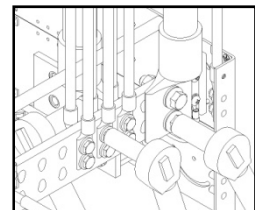

4.4 - Power Verification Test

This test is to verify proper function of the panel prior to the connection of loads.

Turn on the overcurrent protection/disconnect device supplying power to the A side bus. Use a multimeter to verify that voltage and polarity are correct at the input connection. Verify that the PWR LED is illuminated “green”. Verify that continuity is present between C and NC alarm contacts. Install a failed fuse if possible and verify that the LED changes to “red”. With the failed fuse in place verify that continuity is present between C and NO alarm contacts. Repeat these steps for the B side bus if applicable.

Copyright © Trimm, Inc. All rights reserved.

INS-767xxxxxxV Rev C. 03/31/09 High Current Power Distribution Installation Instructions

4.5 - Smart Meter Module

If the unit you are installing includes the optional Smart Meter Module, proceed to the “Smart Meter Module Installation/Calibration Procedure” document (INS-7600210001) prior to installing the output cabling.

Section 5 – Output and Alarm Cabling

WARNING

Before continuing installation, verify that the overcurrent protection/disconnect device is turned “OFF”.

5.1 - Output Wiring

Remove the orange input cover for the position(s) you are wiring by pulling up. Locate and remove the supplied #1/4-20 locking nuts included with this panel. Crimp the wire to the proper compression lug. Attach the wire to the output connection using the supplied nuts and washers. Torque the fasteners to 24 in-lbs. Reattach the output cover for each position by pushing it down over the studs. Label each position on the supplied circuit designation card.

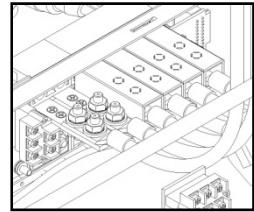

5.2 - Output Wiring (GMT Modules Barrier Strip Type)

This panel accepts up to #10 AWG wire to feed into the equipment and return connections. In tight spaces the set screw connector can be removed by simply loosening the 2 screws securing the connector to its header. Crimp the terminals to the wiring. Remove the screws for each position. Insert the wire onto the corresponding position for both equipment and return connections. Torque the screw to 7 in-lbs.

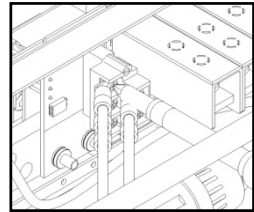

5.3 - Output Wiring (GMT Modules Set Screw Type)

This panel accepts up to #12 AWG wire to feed into the equipment and return connections. In tight spaces the set screw connector can be removed by simply loosening the 2 screws securing the connector to its header. Strip the wire to .375". Loosen the screws for each position. Insert the wire into the corresponding position for both equipment and return connections. Torque screw to 4.5 in-lbs. Label the designation card for each circuit you install.

5.4 - Alarm Wiring

The alarm connector is standard wire wrap pins. Continuity is established at positions C and NC when there is no fuse or power failure. Continuity is established at positions C and NO when a fuse or power failure has occurred.

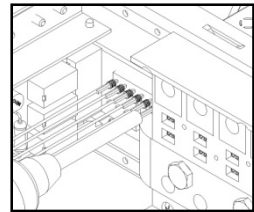

5.5 - Plastic Rear Safety Cover Installation

Reattach the rear plastic safety cover by placing it in the correct position and hand tightening the captive thumb screws. The front cover may be left off until all fuse holders/breakers have been installed.

Section 6 – Final Installation

WARNING

Circuit breakers should be installed as per the image on the right with the single alarm terminal towards the top. Fuse holders may be installed with the alarm terminal at the top or middle position. Failure to do so may result in damage to the equipment, and or personal injury. Circuit breakers should always be installed in the “OFF” position. Fuse holders should always be installed without the fuse in place.

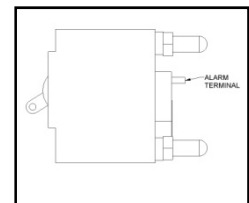

6.1 - Fuse Installation

Orientate and install the correct fuse into its position. Record the protected equipment identification and location on the supplied designation card.

To install circuit breakers or fuse holders remove the front cover if necessary by loosening the 4 captive thumb screws. Orientate the fuse/circuit breaker per the above image. Ensure that the alarm terminal is not bent before installation. Firmly press the fuse holder/circuit breaker's bullet terminals into the corresponding position. Ensure that the bullet contacts are fully inserted and seated on the line and load bus bars. Replace the front cover.

To install Bussmann® TPC, TPW, or GMT fuses, simply push the fuse into the corresponding holder. GMT fuses require the 5 position GMT module.

To install Bussmann® TPS or Littelfuse® TLS fuses, install the fuse into the Canadian Shunt® TFD type fuse holder carrier as shown in the image to the right. These fuses also require a GMT 18/100 A fuse for alarm signaling. Failure to install the alarming fuse will result in a fuse failure without local or remote fuse fail indication.

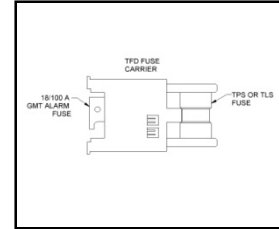

6.2 - Energizing the Panel

Once all steps have been completed above, and a final inspection of the installation has been completed, you may energize the fuse panel by switching the corresponding interrupt device to its "ON" position.

Section 7 – Accessories

GMT FUSES	
PART NUMBER	FUSE AMPERAGE
0300097000	18/100 AMP
0300097001	1/4 AMP
0300097016	3/8 AMP
0300097002	1/2 AMP
0600097065	65/100 AMP
0300097003	3/4 AMP
0300097004	1 AMP
0300097005	1-1/3 AMP
0300097006	1-1/2 AMP
0300097007	2 AMP
0300097008	3 AMP
0300097013	3-1/2 AMP
0300097012	4 AMP
0300097009	5 AMP
0300097011	7-1/2 AMP
0300097010	10 AMP
0300097014	12 AMP
0300097015	15 AMP
0300097100	DUMMY FUSE
0300097209	GMT/X FUSE COVER

767 FAMILY FUSE PANEL ACCEPTED FUSE AND CIRCUIT BREAKER TYPES					
Fuses require holders listed at start of each column (order separately)					
TPC FUSES		TPS FUSES		TLS FUSES	
Uses TPCDS fuse holder part number 0300108180		Uses TFD fuse holder part number 0300108380		Uses TFD fuse holder part number 0300108380	
PART NUMBER	DESCRIPTION	PART NUMBER	DESCRIPTION	PART NUMBER	DESCRIPTION
0300360003	3 AMP	0300350001	1 AMP	0300390001	1 AMP
0300360004	4 AMP	0300350002	2 AMP	0300390003	3 AMP
0300360005	5 AMP	0300350003	3 AMP	0300390005	5 AMP
0300360006	6 AMP	0300350005	5 AMP	0300390006	6 AMP
0300360007	7 AMP	0300350006	6 AMP	0300390010	10 AMP
0300360008	8 AMP	0300350010	10 AMP	0300390015	15 AMP
0300360010	10 AMP	0300350015	15 AMP	0300390020	20 AMP
0300360012	12 AMP	0300350020	20 AMP	0300390025	25 AMP
0300360015	15 AMP	0300350025	25 AMP	0300390030	30 AMP
0300360020	20 AMP	0300350030	30 AMP	0300390035	35 AMP
0300360025	25 AMP	0300350035	35 AMP	0300390040	40 AMP
0300360030	30 AMP	0300350040	40 AMP	0300390050	50 AMP
0300360040	40 AMP	0300350050	50 AMP	0300390060	60 AMP
0300360050	50 AMP	0300350060	60 AMP	0300390070	70 AMP
0300360060	60 AMP	0300350070	70 AMP	0300390080	80 AMP
0300360075	75 AMP	CIRCUIT BREAKERS		0300390090	90 AMP
0300360090	90 AMP	PART NUMBER	DESCRIPTION	0300390100	100 AMP
0300360100	100 AMP	030017760A	5 AMP	0300390125	125 AMP
0300360125	125 AMP	030017760B	7.5 AMP	2 POLE CIRCUIT BREAKERS*	
TPW FUSES (2 pole)		030017760C	10 AMP	PART NUMBER	DESCRIPTION
*Uses TPWDS fuse holder part number 7600108280		030017760D	15 AMP	039017770A	110 AMP
		030017760E	20 AMP	039017770B	120 AMP
PART NUMBER	DESCRIPTION	030017760F	25 AMP	039017770C	130 AMP
0300380150	150 AMP	030017760G	30 AMP	039017770D	140 AMP
0300380175	175 AMP	030017760H	40 AMP	039017770E	150 AMP
0300380200	200 AMP	030017760I	50 AMP	*INCLUDES 2 POLE ADAPTER KIT AND 2 POLE OUTPUT COVER	
0300380225	225 AMP	030017760J	60 AMP		
0300380250	250 AMP	030017760K	70 AMP	BLANK PLUG*	
*HOLDER INCLUDES 2 POLE ADAPTER KIT AND 2 POLE OUTPUT COVER		030017760L	80 AMP	7600161501	
		030017760M	90 AMP		
		030017760N	100 AMP		
*BLANK PLUGS PROTECT UNFILLED POSITIONS					

