

TRIMM, INC.

Document
INS-747xxxxxx

Total Front Access Fuse Panel Installation Guide

This manual covers the following part numbers-
747xxxxxx Family

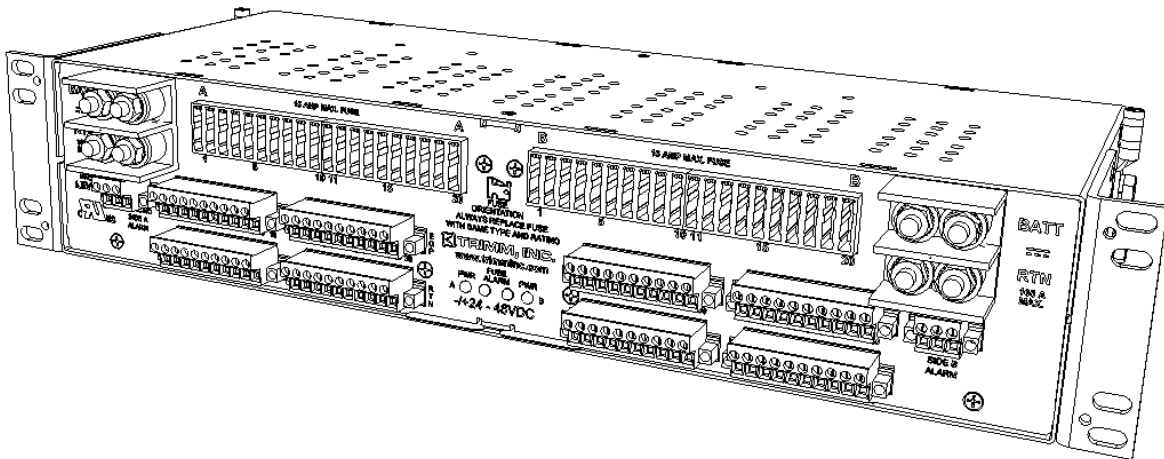

Table of Contents

SECTION 1- GENERAL INFORMATION	3
1.1 - PRODUCT DESCRIPTION	3
1.2 - INSPECTION	3
1.3 - WHAT'S INCLUDED	3
SECTION 2 – BEFORE YOU BEGIN.....	3
2.1 - TOOLS REQUIRED FOR INSTALLATION.....	3
2.2 - INPUT BUS AMPERAGE RATING (GMT PANEL).....	3
2.3 - INPUT BUS AMPERAGE RATING (TPM OR TPA PANEL).....	3
2.4 - FUSE SIZING INFORMATION	4
2.5 - FUSE REPLACEMENT INFORMATION.....	4
2.6 - WIRING TEMPERATURE INFORMATION	4
2.7 - GENERAL NOTES ON TERMINAL CONNECTIONS.....	4
2.8 - TERMINAL INFORMATION	4
SECTION 3 – RACK MOUNTING	4
3.2 - ADDITIONAL RACK MOUNTING INSTRUCTIONS	4
SECTION 4 – INPUT AND GROUNDING CABLING	4
4.1 - CHASSIS GROUNDING (EARTHING)	5
4.2 - INPUT WIRING	5
4.3 - POWER VERIFICATION TEST	5
SECTION 5 – OUTPUT AND ALARM CABLING	5
5.1 - OUTPUT WIRING (GMT PANEL)	5
5.2 - OUTPUT WIRING (TPM PANEL)	5
5.3 - OUTPUT WIRING (TPA PANEL).....	5
5.4 - ALARM WIRING	5
SECTION 6 – FINAL INSTALLATION.....	5
6.1 - FUSE INSTALLATION	5
6.2 - ENERGIZING THE PANEL	5
SECTION 7 – ACCESSORIES.....	6

Section 1- General Information

1.1 - Product Description

Trimm, Inc.'s Total Front Access series of power distribution panels are available with three different fuse types to cover a wide range of applications that require total front access. Total front access design places all input/output connections and fuses on the front of the panel. The GMT panel offers fusing from .18 to 15 Amps per position with up to 20 fused positions per bus. The TPM panel offers fusing from 3 to 30 Amps per position with up to 8 fused positions per bus. The TPA panel offers fusing from 3 to 50 Amps per position with up to 4 fused positions per bus. Power and alarm status are displayed locally with relay contacts for remote fuse fail indication. This product is suitable for central office locations, network telecommunication facilities and data centers.

1.2 - Inspection

Inspect the panel for any noticeable defects, missing parts (See "What's Included" below), or shipping damage. Please notify Trimm, Inc. if any problems are found at 1-800-298-7466. No products may be returned to Trimm, Inc. without the proper Return Material Authorization (RMA) number.

1.3 - What's Included

This unit should be packaged with the following items. Please notify Trimm, Inc. if any of these items are not included so a replacement can be sent out right away.

- Front access fuse panel (verify part number from sticker on right side of unit.)
- 4 x #12-24 x ½" self-tapping mounting screws
- 6 x ¼" flat washers and locking nuts (per bus)
- 6 AWG compression lugs, ¼" bolts and lock washers (For Earthing/grounding connection only.)
- Installation instruction packet

Other items in shipping box may include

- Extra fuses

Section 2 – Before You Begin



WARNING

- This panel should be installed in a restricted access area by qualified service personnel only.
- All connections/methods should meet all national/local electrical codes as well as company specific methods or procedures. Failure to do so may result in damage to the equipment, and or personal injury.
- A readily accessible disconnect device must be incorporated into the supply wiring for this product. This disconnect device must be capable of interrupting the maximum available fault current determined by analysis for your system.

2.1 - Tools Required For Installation

Depending on the part number ordered the following tools are needed to install this product.

- Multimeter
- No. 2 Phillips head torque screw driver
- Torque wrench with 7/16 socket
- Torque wrench with 11/32 thin wall socket (TPA panel only)
- Small slotted torque screw driver
- Suitable crimp tooling for the terminals (TPM/TPA panels only)
- Cable ties or lacing cord
- Writing utensil or label maker for circuit designation
- Wire cutter/stripper

2.2 - Input Bus Amperage Rating (GMT Panel)

This product was designed to be used at its input bus amperage rating of 100 Amps, fed by a 2 AWG wire (maximum allowable wire size is 2/0 AWG) and protected by a 125 Amp overcurrent device. If your required circuit rating is below that, you may size the input wire and interrupt/overcurrent device according to your needs per the National Electrical Code NFPA 70 ampacity tables or your local/company methods and procedures. In the event that this product and its associated wiring/overcurrent device are under the minimum rating, you should re-label over the panel's input bus rating to prevent accidental circuit overloading in the future.

2.3 - Input Bus Amperage Rating (TPM or TPA Panel)

This product was designed to be used at its input bus amperage rating of 150 Amps, fed by a 2/0 AWG wire and protected by a 200 Amp maximum overcurrent device. If your required circuit rating is below that, you may size the input wire and interrupt/overcurrent device according to your needs per the National Electrical Code NFPA 70 ampacity tables or your local/company methods and

procedures. In the event that this product and its associated wiring/overcurrent device are under the minimum rating, you should re-label over the panel's input bus rating to prevent accidental circuit overloading in the future.

2.4 - Fuse Sizing Information

The fuse manufacturer recommends that GMT type fuses rated 8 to 15 Amps be continuously operated at no more than 70% of their nominal current rating.

2.5 - Fuse Replacement Information

The correct fuses may be ordered from the table at the end of this document. See section 7

2.6 - Wiring Temperature Information

The wiring for this product should be rated 90° C or better.

Wiring protected by GMT fuses shall be at least one size larger than the minimum required wire based on the National Electric Code, NFPA 70 ampacity tables.

2.7 - General Notes on Terminal Connections

- Bare conductors should be coated with appropriate antioxidant compound before crimp connections are made.
- Use appropriate shrink tubing over un-insulated terminal barrels.
- Ensure that the mating surface of both the terminals and their connection point are clean and free of paint.
- Appropriate antioxidant should be applied to the mating surfaces of all connections.
- Use only listed terminals and crimp tooling when making connections.

2.8 - Terminal Information

The following terminals or suitable equivalents may be used for connection to this product. Only listed terminals and their recommended crimping tooling should be used. This recommendation is based on the panel's bus amperage rating.

747xxxxxxx Family Suggested Field Wiring Terminals (Code wire)						
Connection	Manufacturer†	Manf. Part Number	Wire Gauge	Stud Size	Hole Spacing	Max. Width
Input (GMT fuse type)	Panduit	LCD2-14A	2 AWG	1/4"	5/8"	.625"
Input (TPA or TPM fuse type)	Panduit	LCDN2/0-14A	2/0 AWG	1/4"	5/8"	.625"
Output (GMT fuse type)	Set Screw (Non required)					
Output (TPM fuse type)	Panduit	PV10-6RX	10-12 AWG	#6	Single Hole	.312"
Output (TPA fuse type)	Panduit	PV8-8RX	8 AWG	#8	Single Hole	.500"
Chassis Ground	Panduit	LCD6-14D	6 AWG	1/4"	1"	.625"
Remote Alarm	Set Screw (Non required)					
†The above list is only a suggestion. Equivalent terminals may be used provided they are listed and crimped with the appropriately listed crimp tooling.						

Section 3 – Rack Mounting

3.1 - Rack Mounting

Secure the panel to the rack using the self tapping screws provided. If the application is for a 23" rack, remove mounting brackets and orientate for 23" rack application.

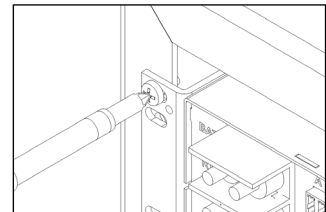

3.2 - Additional Rack Mounting Instructions

If installed in a closed or multi-unit rack assembly, the operating ambient temperature of the rack environment may be greater than room ambient. Therefore, consideration should be given to installing the equipment in an environment compatible with the unit's maximum operating temperature. Mounting of the equipment in the rack should be such that a hazardous condition is not achieved due to uneven mechanical loading.

Section 4 – Input and Grounding Cabling

WARNING

Before installation, verify that the input power disconnect device is turned "OFF"

4.1 - Chassis Grounding (Earthing)

This product is suitable for use in either a Common or Isolated (CBN or IBN) Bonding Network. This panel includes 6 AWG compression lugs for grounding. Crimp the ground wire to the terminals provided. Attach the wires to the panel using the supplied bolts and lock washers. Torque fasteners to 24 in-lbs. Attach other end of ground pigtail to the rack or other suitable grounding location. Reliable Earthing of rack-mounted equipment should be maintained.

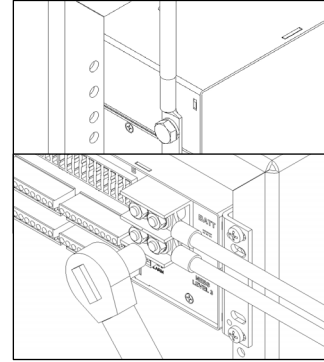

4.2 - Input Wiring

Remove the input covers and locate the #1/4 flat washers and #1/4-20 locking nuts supplied with this panel. Crimp the battery and return wires to the proper terminals. Attach the wires to the panel using the supplied flat washers and locking nuts. Torque the fasteners to 50 in-lbs. This product is suitable for use with either common or isolated (DC-C or DC-I) treatment of the battery return connection.

4.3 - Power Verification Test

This test is to verify proper function of the panel prior to the connection of loads. Turn on the overcurrent protection/disconnect device supplying power to the A side bus. Use a multimeter to verify that voltage and polarity are correct at the input connection. Verify that the PWR LED is illuminated "green" and FUSE ALARM LED is not illuminated. Verify that continuity is present between C and NC alarm contacts. Install a failed fuse if possible and verify that the FUSE ALARM LED changes to "red". With the failed fuse in place verify that continuity is present between C and NO alarm contacts. Repeat these steps for the B side bus if applicable.

Section 5 – Output and Alarm Cabling



Before continuing installation, verify that the overcurrent protection/disconnect device is turned "OFF"

5.1 - Output Wiring (GMT Panel)

This panel accepts up to #12 AWG wire to feed into the equipment and return connections. Strip the wire to .375". Loosen the screws for each position. Insert the wire into the corresponding position for both equipment and return connections. Torque the screw to 4.5 in-lbs.

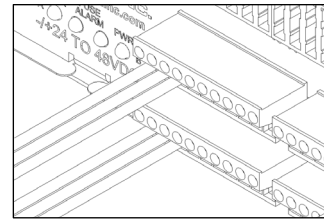

5.2 - Output Wiring (TPM Panel)

This panel accepts up to #10 AWG wire to feed into the equipment and return connections. Crimp the terminals to the wiring. Remove the screws for each position. Insert the wire onto the corresponding position for both equipment and return connections. Torque the screw to 7 in-lbs.

5.3 - Output Wiring (TPA Panel)

This panel accepts up to #8 AWG wire/terminals to feed into the equipment and return connections. Crimp the terminals to the wiring. Remove the nuts for each position. Insert the wire onto the corresponding position for both equipment and return connections. Torque nut to 10 in-lbs.

5.4 - Alarm Wiring

The alarm connector accepts #12-22 AWG stranded/solid wire. Strip end of wire to .375", insert into corresponding positions of the alarm connector. Torque screw to 4.5 in-lbs. Continuity is established at positions C and NC when there is no fuse failure. Continuity is established at positions C and NO when a fuse failure has occurred.

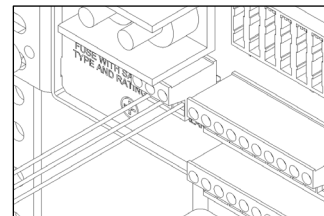

Section 6 – Final Installation

6.1 - Fuse Installation

Orientate and install the correct fuse into its position. Record the protected equipment identification and location on the supplied designation card.

6.2 - Energizing the Panel

Once all steps have been completed above, and a final inspection of the installation has been completed, you may energize the fuse panel by switching the corresponding interrupt device to its "ON" position.

Section 7 – Accessories

GMT FUSES					
PART NUMBER	FUSE AMPERAGE				
0300097000	18/100 AMP				
0300097001	1/4 AMP				
0300097016	3/8 AMP				
0300097002	1/2 AMP				
0600097065	65/100 AMP				
0300097003	3/4 AMP				
0300097004	1 AMP				
0300097005	1-1/3 AMP				
0300097006	1-1/2 AMP				
0300097007	2 AMP				
0300097008	3 AMP				
0300097013	3-1/2 AMP				
0300097012	4 AMP				
0300097009	5 AMP				
0300097011	7-1/2 AMP				
0300097010	10 AMP				
0300097014	12 AMP				
0300097015	15 AMP				
0300097100	DUMMY FUSE				
0300097209	GMT/X FUSE COVER				
		TPM FUSES			
		PART NUMBER	FUSE AMPERAGE		
		7500192703	3 AMP		
		7500192704	4 AMP		
		7500192705	5 AMP		
		7500192706	6 AMP		
		7500192707	7 AMP		
		7500192708	8 AMP		
		7500192710	10 AMP		
		7500192712	12 AMP		
		7500192715	15 AMP		
		7500192720	20 AMP		
		7500192725	25 AMP		
		7500192730	30 AMP		
				TPA FUSES	
				PART NUMBER	FUSE AMPERAGE
				7500192003	3 AMP
				7500192005	5 AMP
				7500192010	10 AMP
				7500192015	15 AMP
				7500192020	20 AMP
				7500192025	25 AMP
				7500192030	30 AMP
				7500192040	40 AMP
				7500192050	50 AMP