



Heat Baffle Installation Guide

Document INS-300HBxxxxx

This manual covers the following part numbers-
Trimm *300HBxxxxx* Family

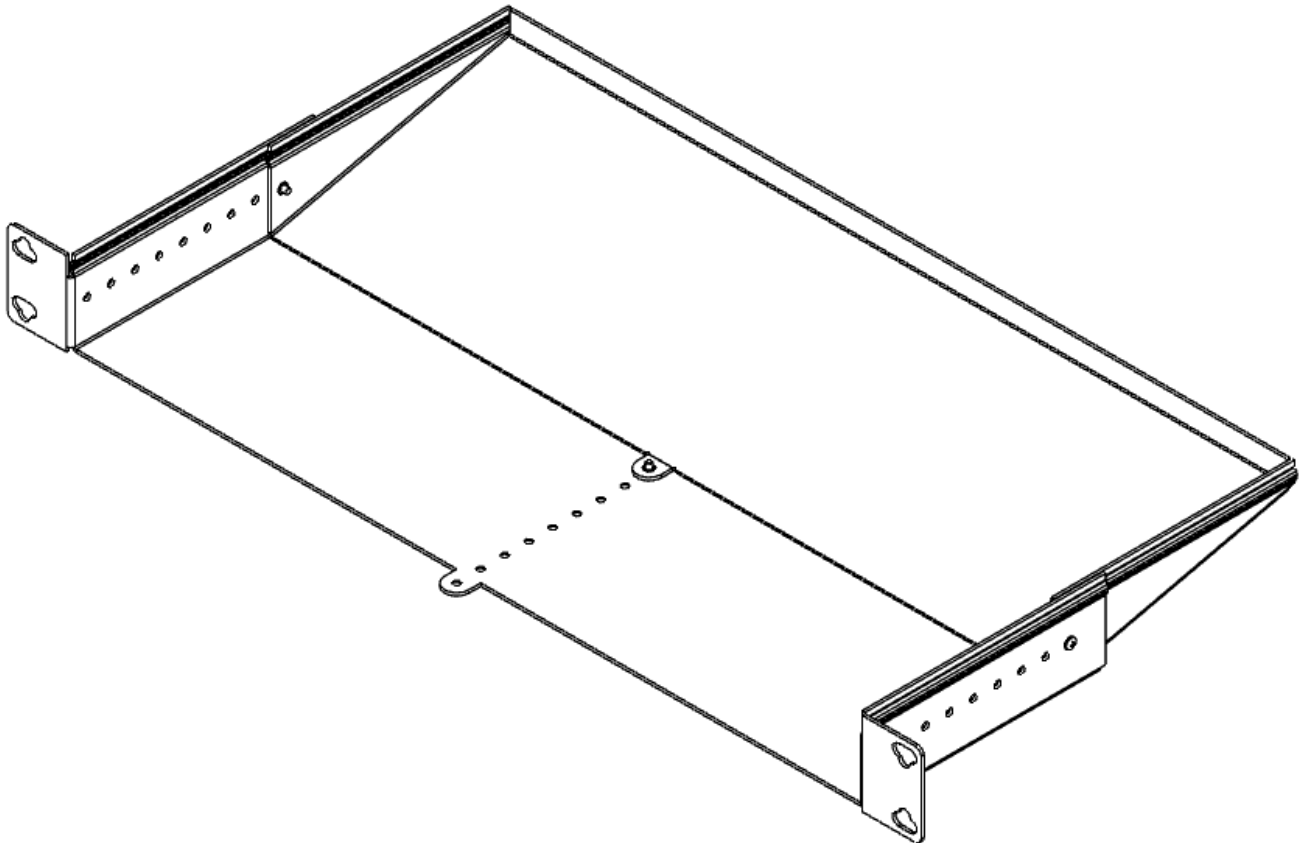

Table of Contents

- Section 1- General Information 3**
 - 1.1 - Product Description 3
 - 1.2 - Inspection..... 3
 - 1.3 - What's Included 3
- Section 2 – Before You Begin 3**
 - 2.1 - Tools Required For Installation..... 3
- Section 3 – Rack Mounting..... 3**
 - 3.1 – Depth Adjustment (for adjustable versions only) 3
 - 3.2 – Offset Mounted Equipment 4
 - 3.3 – Rack Mounting 4
- Section 4 - Revision Record 4**

Section 1- General Information

1.1 - Product Description

Trimm, Inc.'s heat baffles are used under fuse panels or other equipment to help direct rising hot air away from the equipment. The baffle is open on the front to allow air to be drawn in from the cooler "cold aisle", and ramped on the bottom to allow the rising hot air from other equipment lower in the rack to be directed back and away from the equipment. Heat baffles are available in fixed as well as adjustable depth configurations. Adjustable versions are factory configured with the baffles in the fully extended (maximum depth) position.

1.2 - Inspection

Inspect the product for any noticeable defects, missing parts (See "What's Included" below), or shipping damage. Please retain the original packaging in case you need to return the product to Trimm, Inc. Please notify Trimm, Inc. if any problems are found at 1-800-298-7466. Products shall not be returned to Trimm, Inc. without the proper Return Material Authorization (RMA) number.

1.3 - What's Included

The unit should be packaged with the following items. Please notify Trimm, Inc. if any of these items are not included so a replacement can be sent out right away.

- Heat baffle (verify part number from sticker on unit.)
- #12-24 x ½" self-tapping mounting screws for rack mounting
- Installation instruction packet

Section 2 – Before You Begin

2.1 - Tools Required For Installation

Depending on the part number ordered the following tools may be needed to install this product.

- No. 1 Phillips head torque screw driver (for adjustable version only)
- No. 2 Phillips head torque screw driver

Section 3 – Rack Mounting

3.1 – Depth Adjustment (for adjustable versions only)

Adjustable baffle versions allow the overall depth to be changed to support differing equipment depths. To adjust the depth, loosen and remove the 3 x screws (1 on each side and 1 on the bottom) of the baffle. Slide the baffle to the new depth required by your equipment and re-install/torque the screws to 3 in-lbs. (.35 Nm) max. It is recommended that the baffle be flipped over and placed on a flat surface during adjustment to ensure that the flange sealing surfaces of the 2 halves of the baffle remain parallel/straight. Baffles should be adjusted to ensure adequate spacing between the rear of the baffle and any terminals or other electrically energized parts.

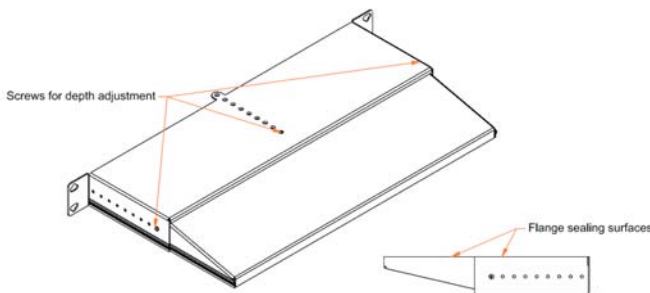

3.2 – Offset Mounted Equipment

Adjustable baffle versions also support offset mounted equipment. The following illustration shows a typical implementation with offset mounted equipment. Note that the equipment extends forward but the baffle is still mounted flush with the racks mounting surface. The baffle has been adjusted to extend to just before the end of the equipments enclosure. Fixed depth baffles may be used with offset mounted equipment provided that the equipment is deep enough to extend past the rear of the baffle.

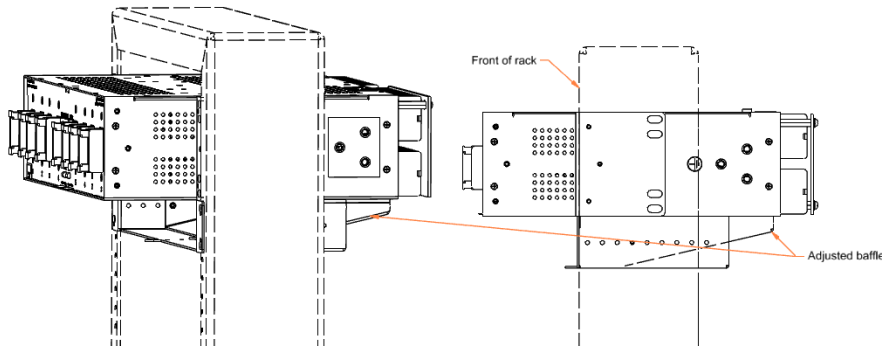

3.3 – Rack Mounting

The equipment should already be mounted prior to baffle installation. The heat ramp always goes under the equipment with the ramp mounted against the bottom. The rear of the ramp should cover the holes in the bottom of the chassis but not protrude beyond the rear. Locate the #12-24 mounting screws provided with the panel. Place the baffle into position under the equipment with the ramped portion extending up towards the rear of the equipment and torque mounting screws to 24 in-lbs. (2.7 Nm) max. The baffle should be pressed firmly up against the bottom surface of the equipment. This will allow the best possible seal preventing rising hot air from making its way into the equipment enclosure. For 23” racks, please order Trimm, Inc. 19” to 23” rack adapter kit part number # 0300163121 (1 kit per baffle). Typical “flush” mount/standard application shown below.

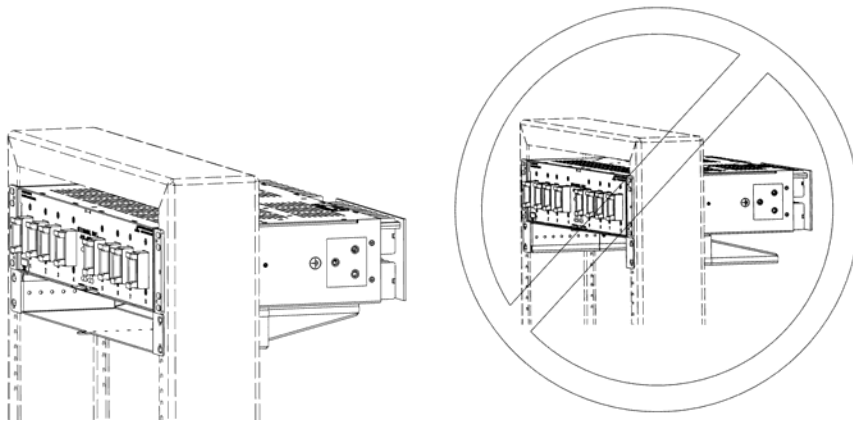

Correct Installation

Incorrect Installation

Section 4 - Revision Record

Legend: Type R=Revision A=Addition D=Deletion
 T=Typo N=New V=Review

Revision	Date	Type	Section/Comments
----------	------	------	------------------

A	01/16/13	N	New Document
---	----------	---	--------------